

“Boost-A-Break” - Break Tank & Booster Sets

Model BTAB – Fixed and Variable Speeds – Datasheet Page 1 of 5

Overview

Break Tank assembly with Fluid Category 5 protection by virtue of the integral Type AB air gap. The unit is supplied as a complete package on a stainless base ready for installation.

The primary purpose is to provide backflow protection in accordance with the new Water Regulations. The BTAB unit also boosts the water pressure for elevated areas or where a high flow rate is required – e.g. wash-down.

The cistern has a screened overflow and weir, making it suitable for unorthodox drinking water applications, which require a “Hygienic type AB air gap” – e.g. dental spittoons & food preparation.

The unit is quiet by virtue of a centrifugal pump, anti-vibration rubber feet and flexible stainless braided connection hoses. There is a range of fixed and variable speed (inverter) pumps. The variable speed range has the compactness of the fixed speed range plus additional benefits – see page 3.

For higher flow rates and variable speed pumps see page 3.
For domestic boosting use “Pent-A-Boost” model BTAF.

Applications

The following are Fluid Category 5 examples see Water Regulations (Table 6.1e) -

- Waste bin washing
- Hose union taps – non-domestic
- Wash-down – animals or any Fluid Category 5
- Underground or surface irrigation – see HUBG datasheet
- Laboratories
- Baths in health care premises
- Showers health care – see Care Shower datasheet
- Sinks with hoses
- Bidets
- Bedpan washing
- Dental equipment
- Vegetable washing
- Butchery & meat equipment / Slaughterhouse
- Clothes washing machines – healthcare premises
- Dish washing machines – healthcare premises
- Applications deemed to be Category 5 by water company

Water Regulations

The assembly is fully Water Regulations approved & complies with the requirements of the new Water Regulations when installed and used correctly. A Break Tank with a Type AB air gap provides protection against Fluid Category 5 risks - these risks are the highest level. “Boost-A-Break” can therefore be used for all applications – use “Pent-A-Boost” for drinking water.

The Regulations require point of use protection. For example, it is not permissible to use the same Break Tank to serve a bedpan washer (Fluid Category 5) and a dishwasher. However several appliances of the same type can be served from the same Break Tank unit – e.g. irrigation.

Specification

Pressure Supply min.	1.2 bar min. maintained (dynamic)
Pressure Supply max.	10 bar
Pressure Outlet	See flow graph – page 2
Pressure Gauge	63 dia. stainless – glycerine filled
Vessel Capacity	24 Lt
Cistern Capacity	18 Lt (except 5 series) 24 Lt (5-4, 5-8, 5-10, 5-16)
Inlet Size	See “Inlet Control” table
Outlet Size	See “Outlet Pressure Control” table
Noise	<70 dBa @ 1 m
Temperature	25° max. ambient
Approval (complete)	KIWA UK 0903703



Model 1200
Fixed speed
Note: stainless -
screened slot,
drip tray, base,
and hoses. Only
675 mm high



Model 5-8
Variable speed
Stainless tank, twin
inlet solenoid.
Height 775 mm.
High flow
2 Lt/s output



Optional Wall
Brackets
Stainless steel tray
with galvanised
brackets code
BTBRA.
Second set can be
located underneath
on floor



Optional Wall
Cover code
BTCAB3 (brackets
required code
BTBRA).
Provides thermal
protection and
guards Break Tank
against tampering
and pests.
Ideal for bin stores

Materials

Base / drip tray / fasteners	Stainless steel 304
Pump (wetted parts)	Stainless steel 304
Pipes / fittings	Copper / Brass / Stainless
Cistern 18 Lt	Polypropylene
Cistern 24 Lt	Stainless steel 304

Arrow Valves Ltd

Tel: 01442 823123 Fax: 01442 823234
www.arrowvalves.co.uk
info@arrowvalves.co.uk

Arrow Valves Ltd reserve the right to change specifications, design and materials at any time without notice.
All unit-less dimensions in mm.
© Copyright Arrow Valves Ltd 2001-2012



“Boost-A-Break” – Break Tank & Booster Set

Model BTAB – Fixed Speed 700, 900, 1200, 4-2, 4-3, 4-4 - Datasheet Page 2 of 5

Description – Fixed Speed

There is a choice of six pump duties – see chart. The units are compact and the pump operation is automatically controlled. The initial cost of fixed speed pumps is less than the equivalent variable speed but fixed speed pumps generally consume more energy over a lifetime. For low use applications or where the demand is high and near constant, a fixed speed pump is adequate. The pumps are self priming.

The relatively large 24 litre pressure vessel allows about 5 litres of water to be supplied before the pump switches on.

Inlet Control

Fast and accurate level control is achieved with a solenoid valve. Electrodes provide on/off full flow control with 60 mm delayed action. The DN20 inlet is equivalent to ten ½” BS1212 HP float valves. DN25 is fitted as standard to high flow models - see table below – and optional on others – e.g. for low pressure supplies. Providing the following minimum dynamic supply pressure is maintained at the inlet, the cistern will not run dry even with an open outlet.

Model	Inlet Size	Minimum Dynamic Pressure	Pipe Velocity m/s
700, 900	DN20 female union	1.0 bar	3.7
1200, 4-2, 4-3, 4-4	DN25 female union	1.0 bar	2.8

Outlet Pressure Control

The pressure switch is factory set according to the table below. To stabilise the outlet pressure, a factory fitted Pressure Regulating Valve (PRV) is optional – code BTPRV.

The outlet flow is automatically limited to 1.17 or 1.5 Lt/s for 4 series.

Model	Outlet Size	Pressure Switch on (min.)	Outlet with Optional PRV ¹	Pressure Max ² .	Vessel Pressure ³
700	DN20	2.0 bar	2.0 bar	3.3 bar	1.8 bar
900	DN20	3.0 bar	3.0 bar	4.5 bar	2.8 bar
1200	DN20	4.0 bar	3.0 bar	5.7 bar	3.8 bar
4-2	DN20	1.0 bar	1.0 bar	2.3 bar	0.8 bar
4-3	DN20	2.0 bar	2.0 bar	3.4 bar	1.8 bar
4-4	DN20	3.0 bar	3.0 bar	4.5 bar	2.8 bar

Notes - 1. Adjustable. 2. Without PRV 3. Vessel air pressure with zero water pressure.

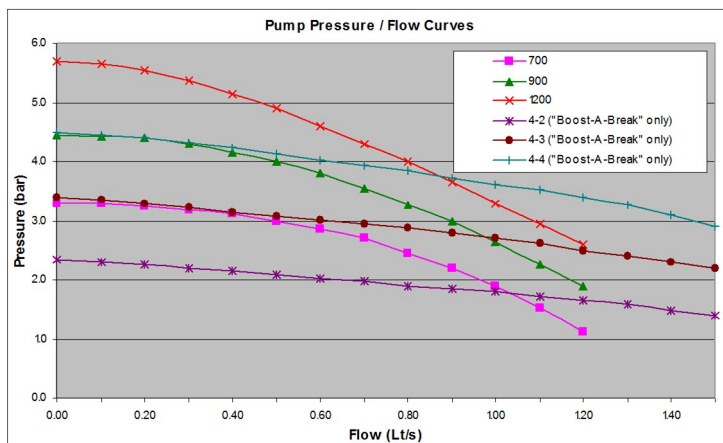

Electrical Specification

Motor	2 – Pole 50 Hz IP54
Model	230 V 1 ph or 400 V 3 ph
700	3.0 A (9.8 start) 1 ph or 2.4 A 3 ph
900	4.2 A (13.8 start) 1 ph or 2.8 A 3 ph
1200	5.4 A (18.0 start) 1 ph or 3.5 A 3 ph
4-2	3.0 A (9.8 start) 1 ph or 2.4 A 3 ph
4-3	4.2 A (13.8 start) 1 ph or 2.8 A 3 ph
4-4	5.4 A (18.0 start) 1 ph or 3.5 A 3 ph
Class	Class 1 (requires earth wire)
Run-on Timer	180 sec
BMS	Volt free SPDT for low level alarm
Low level cut out	Stops pump via electrodes in tank (Warning lamp on control box) – auto reset once tank refilled
Connection	M20 hole in control box
Protection	IP65 (Enclosure) / IP54 (Pump)

Dimensions

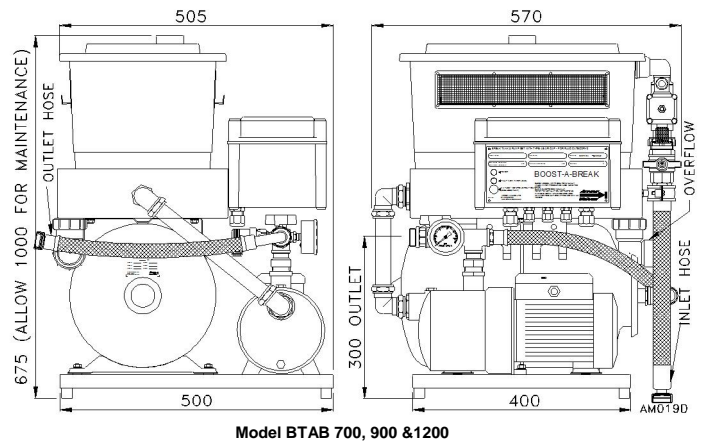

Kg Dry	Kg Gross	Base Width	Base Depth
28 - 36	68 - 74	400	500

Connection Pipes

Flexible stainless braided hoses are supplied for the inlet and outlet. These have a female swivel nut (union) and a fibre washer. See Inlet Control and Outlet Pressure Control tables for size. A full bore inlet servicing valve – as required by the Regulations (G16.4) - is fitted upstream of the solenoid filling valve. The Overflow is 40 mm plastic with compression nut.

Codes and Descriptions – Fixed Speed

Inlet Size	Code	Description
DN20	BTAB700	Boost-A-Break AB Gap 700 Fixed 230 V
DN20	BTAB900	Boost-A-Break AB Gap 900 Fixed 230 V
DN25	BTAB1200	Boost-A-Break AB Gap 1200 Fixed 230 V
DN25	BTAB4-2	Boost-A-Break AB Gap 4-2 Fixed 230 V
DN25	BTAB4-3	Boost-A-Break AB Gap 4-3 Fixed 230 V
DN25	BTAB4-4	Boost-A-Break AB Gap 4-4 Fixed 230 V

Optional extras – see page 5

Arrow Valves Ltd

Tel: 01442 823123 Fax: 01442 823234

www.arrowvalves.co.uk

info@arrowvalves.co.uk

Arrow Valves Ltd reserve the right to change specifications, design and materials at any time without notice.

All unit-less dimensions in mm.

© Copyright Arrow Valves Ltd 2001-2012



“Boost-A-Break” – Break Tank & Booster Set

Model BTAB – Variable Speed 3-5, 3-7, 3-10, 5-4, 5-8, 5-10, 5-16 - Datasheet Page 3 of 5

Description – Variable Speed

Variable speed pumps provide only the pressure required to meet demand making the unit economical and extending the lifespan of the pump.

There is a choice of 7 variable speed pumps – see chart. The variable speed range has all the benefits of the fixed speed pumps plus -

- Higher flow rate – up to 2 Lt/s output
- Variable speed – speed changes to meet demand
- Quiet – especially at low demand
- Surge free – inverter pump avoids high current demand
- Constant supply pressure
- Electronically controlled automatic pump venting system

Inlet Control

Fast and accurate level control is achieved with solenoid valve(s). Level electrodes provide on/off full flow control with 60 mm delayed action. The DN32 inlet on the 5 series is equivalent to more than thirty ½” BS1212 HP float valves.

Model	Inlet Size	Minimum Dynamic Pressure	Pipe Velocity m/s
3-5, 3-7	DN20 female union	1.0 bar	3.7
3-10, 5-4	DN25 female union	1.0 bar	2.8
5-8, 5-10, 5-16	DN32 female union	1.0 bar	2.4

Outlet Pressure Control

The outlet pressure is controlled by a transducer, which is factory set to the “default set point” in the table below and controlled to within a 10% band. The outlet pressure is therefore constant up to the maximum duty of the pump.

Model	Outlet Size	Default Set point	Pressure Switch on (min.) ¹	Pressure Switch off (Max) ¹	Pressure Max ²	Vessel Air Pressure ³
3-5	DN20	2.0 bar	1.8 bar	2.2 bar	3.2 bar	1.4 bar
3-7	DN20	3.0 bar	2.7 bar	3.3 bar	4.6 bar	2.1 bar
3-10	DN25	4.0 bar	3.6 bar	4.4 bar	6.5 bar	2.8 bar
5-4	DN25	1.5 bar	1.4 bar	1.7 bar	2.7 bar	1.1 bar
5-8	DN32	3.0 bar	2.7 bar	3.3 bar	5.4 bar	2.1 bar
5-10	DN32	4.0 bar	3.6 bar	4.4 bar	6.8 bar	2.8 bar
5-16	DN32	6.0 bar	5.4 bar	6.6 bar	10.9 bar	4.2 bar

Notes - 1. Differential +/- 10% of set point. 2. If set to full speed. 3. Vessel air pressure with zero water pressure, 0.7 X set point.

The graph below illustrates the benefit of variable speed pumps. The outlet pressure is constant despite varying flow demand. Note – using “default set point”. The set point can be altered at the factory. On-site alterations require a commissioning service. 5-16 limited to 10 bar.

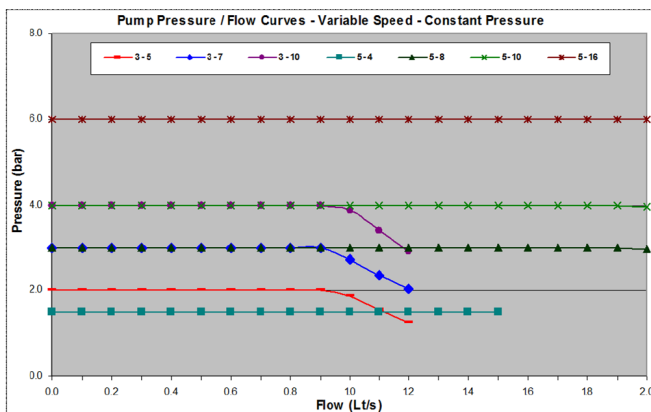

Electrical Specification

Motor	230 V 1 ph (3 series & 5-4, 5-8) 415 V 3 ph (5-10, 5-16)
3-5	3.0 A 1 ph
3-7	4.3 A 1 ph
3-10	5.1 A 1 ph
5-4 (inverter)	4.3 A 1 ph
5-8 (inverter)	7.4 A 1 ph
5-10 (inverter)	3.3 A 3 ph
5-16 (inverter)	4.6 A 3 ph
Class	Class 1 (requires earth wire)
BMS	Volt free SPDT relay general fault - pump / inverter / low level alarm
Low level cut out	Stops pump via electrodes in tank (Warning lamp on control box) – auto reset once tank refilled
Protection	IP65 (Enclosure) / IP55 (Pump)

Connection

1 phase	M20 1 phase + neutral + earth
3 phase ¹	M20 3 phases + neutral + earth

Note – 1. The control circuit is 230 V so a neutral supply is required

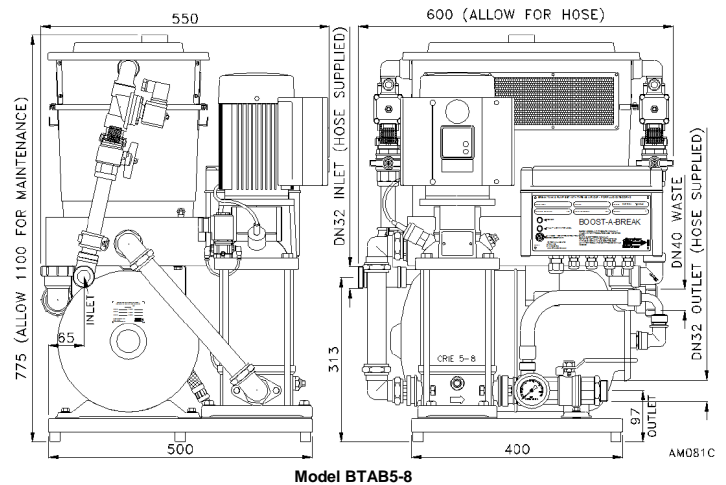

Kg Dry	Kg Gross	Base Width	Base Depth
46 - 85	86 - 125	400	500

Connection Pipes

Flexible stainless braided hoses are supplied for the inlet and outlet. These have a female swivel nut (union) and a fibre washer. See Inlet Control and Outlet Pressure Control tables for size. A full bore inlet servicing valve – as required by the Regulations (G16.4) - is fitted upstream of the solenoid filling valve. The Overflow is 40 mm plastic with compression nut.

Codes and Descriptions – Variable Speed

Inlet Size	Code	Description
DN20	BTAB3-5	Boost-A-Break AB Gap 3-5 Variable 230 V
DN20	BTAB3-7	Boost-A-Break AB Gap 3-7 Variable 230 V
DN25	BTAB3-10	Boost-A-Break AB Gap 3-10 Variable 230 V
DN25	BTAB5-4	Boost-A-Break AB Gap 5-4 Variable 230 V
DN32	BTAB5-8	Boost-A-Break AB Gap 5-8 Variable 230 V
DN32	BTAB5-10	Boost-A-Break AB Gap 5-10 Variable 415 V
DN32	BTAB5-16	Boost-A-Break AB Gap 5-16 Variable 415 V

Optional extras – see page 5

“Boost-A-Break” – Break Tank & Booster Set

Model BTAB – Dual Pump - Duty Assist & Duty Standby – Datasheet Page 4 of 5

Description – Dual Pump

Dual pump sets are available as Duty Standby or Duty Assist. Both pumps are variable speed and set to provide constant pressure. Remarkably, the foot print is the same as the single pump set yet the duty is up to 2.4 Lt/s. The parallel mounted pumps draw water from the integral ultra-fast filling tank.

The cistern has a screened overflow and weir, making it suitable for unorthodox drinking water applications, which require a “Hygienic type AB air gap”.

Duty Standby - only one pump runs at any one time. The pumps alternate on a daily basis to avoid stagnation and ensure even use. A manual override switch “hand” allows either pump to be isolated and run only the healthy pump.

Duty Assist - allows the second pump to automatically switch on when required, thus doubling the output. Alternate starting avoids stagnation and ensures even use. If one pump develops a fault, the controller isolates and continues with the healthy pump (the BMS fault relay activates together with panel lamps). Normal demand is often met with only one small pump running at optimum efficiency, offering substantial energy saving compared to one larger pump. Furthermore smaller pumps are quieter.

Model 3-7
Dual Pump
Duty Assist
Quiet and efficient
2.4 Lt/s output



Model	Outlet Size	Default Set point	Pressure Switch on (min.) ¹	Pressure Switch off (Max) ¹	Pressure Max ²	Vessel Air Pressure ³
Duty Standby						
3-7	DN20	3.0 bar	2.7 bar	3.3 bar	4.6 bar	2.1 bar
3-10	DN25	4.0 bar	3.6 bar	4.4 bar	6.5 bar	2.8 bar
5-4	DN25	1.5 bar	1.4 bar	1.7 bar	2.7 bar	1.1 bar
5-8	DN32	3.0 bar	2.7 bar	3.3 bar	5.4 bar	2.1 bar
Duty Assist						
3-7	DN32	3.0 bar	2.7 bar	3.3 bar	4.6 bar	2.1 bar
3-10	DN32	4.0 bar	3.6 bar	4.4 bar	6.5 bar	2.8 bar

Notes -
1. Differential +/- 10% of set point. 2. If set to full speed.
3. Vessel air pressure with zero water pressure, 0.7 X set point.

Specification & Materials

See page 1 and 3

Electrical Specification

Voltage 230 V 1 phase
Protection MCB in control box for each pump
motors thermal protection (IEC 34-11: TP 211)
3-7 Duty Assist 2 x 4.3 = 8.6 A
3-10 Duty Assist 2 x 5.1 = 10.2 A
Class Class 1 (requires earth wire)
BMS Volt free SPDT relay general fault-pump / inverter / low level alarm
Volt free SPDT for low level alarm
Stops pump via electrodes in tank (Warning lamp on control box) – auto reset once tank refilled
IP65 (Enclosure) / IP55 (Pump)

Low level cut out

Protection Connection

1 phase M20 1 phase + neutral + earth

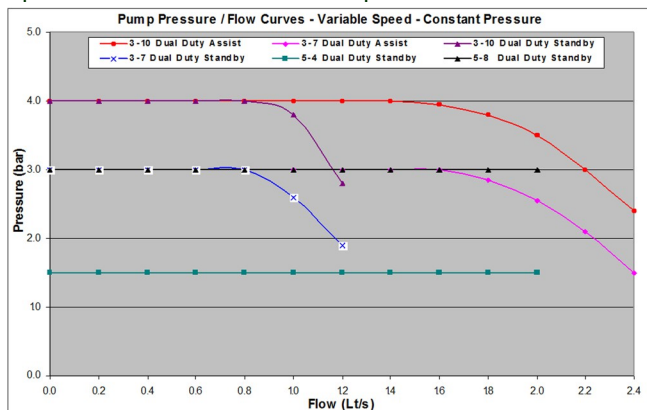

Dimensions

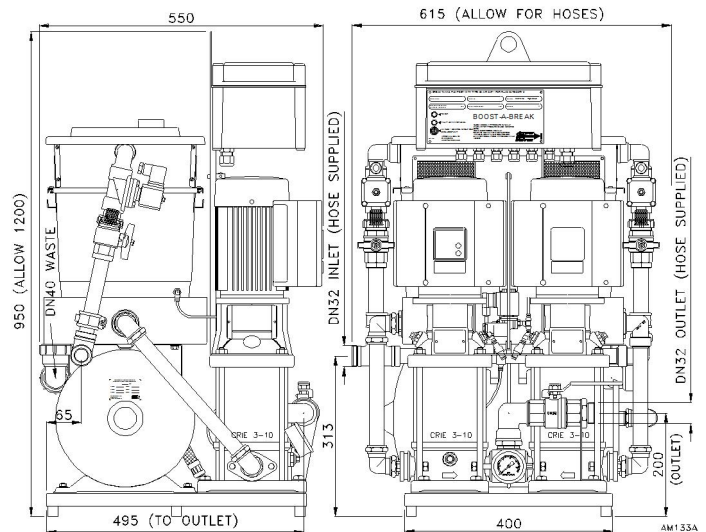

Model BTAB3-7 Duty Assist

Codes and Descriptions – Dual Pump

Inlet Size	Code	Description
DN20	BTAB3-7S	Boost-A-Break 3-7 Duty Standby Vari 230 V
DN25	BTAB3-10S	Boost-A-Break 3-10 Duty Standby Vari 230 V
DN25	BTAB5-4S	Boost-A-Break 5-4 Duty Standby Vari 230 V
DN32	BTAB5-8S	Boost-A-Break 5-8 Duty Standby Vari 230 V
DN32	BTAB3-7A	Boost-A-Break 3-7 Duty Assist Vari 230 V
DN32	BTAB3-10A	Boost-A-Break 3-10 Duty Assist Vari 230 V

Arrow Valves Ltd

Tel: 01442 823123 Fax: 01442 823234

www.arrowvalves.co.uk

info@arrowvalves.co.uk

Arrow Valves Ltd reserve the right to change specifications, design and materials at any time without notice.

All unit-less dimensions in mm.
© Copyright Arrow Valves Ltd 2001-2012



“Boost-A-Break” - Break Tank & Booster Set

Model BTAB – Options – Datasheet Page 5 of 5

Options

- Break tank high level alarm- Recommended to minimise the risk of water damage, by BMS warning when the tank is excessively full.
- Pressure Regulating Valve (PRV) – constant outlet pressure – factory fitted – *fixed speed only*
- Wall Brackets – *not suitable for 5-10, 5-16 or duals*
- GRP Drip Trays – see “Pent-A-Boost” datasheet
- GRP Wall Covers – use wall brackets – e.g. bin store
- GRP Enclosure – for exterior use
- 3 phase pumps – *standard on 5-10 and 5-16*
- Pulse timer – prevents pump sticking if infrequently used – *all except dual*
- Additional expansion vessel – reduces pump starts
- Wash down guns – industrial brass rubber coated

Suitability	Code	Description
Up to 5-8 single	BTBRA	Wall Bracket for Break Tanks AV Mounts
All except dual	BTPT	Pulse Timer - Infrequent Use/Anti Seize
All DN20	BT20-25	Upgrade from DN20 to DN25 Solenoid
All fixed speed	BT2-3	Upgrade to 3 phase pump
Up to 3-7 single	BTDT1	GRP Drip Tray c/w Float Switch (up to 3-7)
Up to 3-7 single	BTDT2	Controller & Additional Sol for Drip Tray
All fixed speed	EVUP100V	Exp. Vessel 10 bar Ø450X910 High Vert
All fixed speed	BTPRV	PRV for Fixed Speed Break Tank
All	BTCAB1	Enc. 1100x1100x1050 GRP c/w Heating
All Single	BTCAB2	Enc. 660x600x780 GRP c/w Frost Protection
Up to 5-8 Single	BTCAB3	BT Wall Cover 1035hx735Wx610D
Fixed Speed	BTBMS1	BT High alarm BMS –Fixed speed pumps
Variable Speed	BTBMS2	BT High alarm BMS – Variable speed pumps

GRP Enclosure – Dimensions

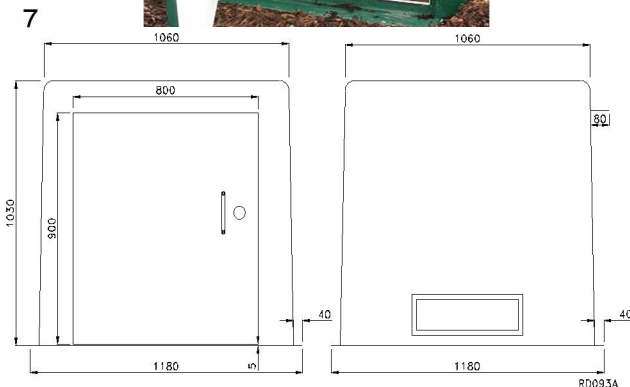

Wall Brackets BTBRA – Dimensions

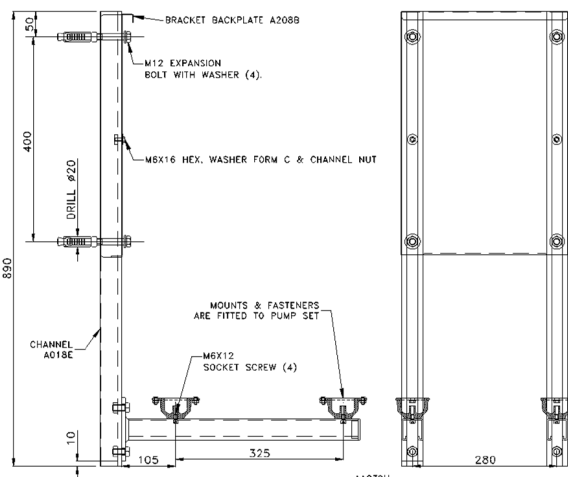

Wall Cover – Dimensions

(Not suitable for 5-10, 5-16 or duals)

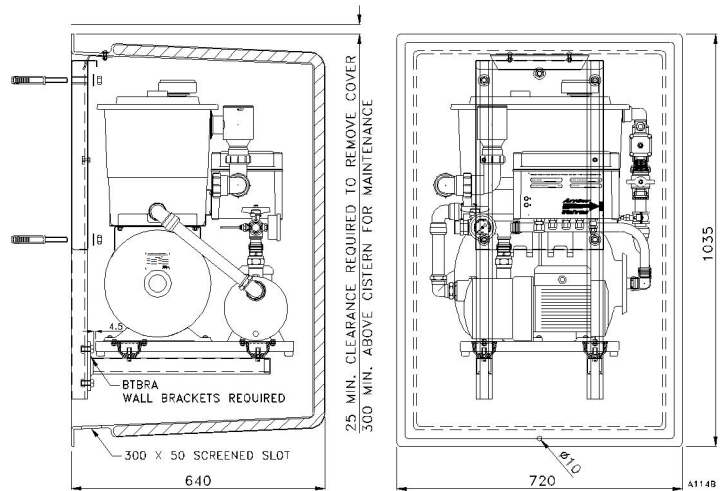

Installation Notes

The unit must be located in a frost-protected area that is not liable to flooding – heated GRP housings available. The unit is generally floor mounted on standard rubber feet. Alternatively use the special wall brackets which feature special acoustic mounts. Where possible mount to a solid external wall.

All controls and serviceable components are accessible from the front, so allow room for servicing. The vessel air charge valve is located on the left.

The flexible stainless hose provided should be connected to a supply pipe. Thoroughly flush pipes before connecting.

40 mm plastic - or 42 mm copper - overflow pipe should be connected to the compression elbow fitted to the drip tray. The pipe should be as short as possible and slope down. Note the 5 series have two DN40 overflow connections from the stainless drip tray. Both should be connected.

The unit must be hardwired through a 2 pole isolator (4 pole for 3 phase) and protected with a suitable MCB.

The pump will not run until the cistern is almost full. If pump does not stop after 4 minutes with outlet valve closed, isolate power for 20 seconds then switch on. This assists with self-priming.

Check the pump switches on and off at the required pressures using the (glycerine filled) gauge fitted.

Arrow Valves Ltd

Tel: 01442 823123

Fax: 01442 823234

www.arrowvalves.co.uk

info@arrowvalves.co.uk

Arrow Valves Ltd reserve the right to change specifications, design and materials at any time without notice.

All unit-less dimensions in mm.
© Copyright Arrow Valves Ltd 2001-2012

