

Thermostatic Mixing Valve

Model 5213 – Datasheet - Page 1 of 2

Description

Model TMV5213 is particularly compact whilst retaining the benefits of union inlet connections and integral check valves. The 15 mm valve is DO8, TMV3 and WRAS approved.

TMVs blend hot and cold water at point of use to provide warm water to basins, showers and baths. When installed and maintained correctly, the TMV will fulfil the Duty of Care requirements against scalding. Legionella bacteria breed in warm water (20-45°C), so to avoid this condition hot water should be stored at 60-65°C and distributed at not less than 55°C. The cold water should be supplied below 20°C. *Legionella bacteria die within 32 mins in water @ 60°C.*

Proportional control on both the hot and cold provides an accurate ($\pm 2^\circ\text{C}$) outlet temperature, which is adjustable between 30–50°C by means of a tamperproof adjustment. Low head loss check valves are incorporated into the hot and cold tails, which provide the necessary backflow protection against hot water (Fluid Category 2). *Note – when used for a bath with a shower hose additional backflow protection is necessary, see tutorial # 8 on the our website www.arrowvalves.co.uk*

Flat-faced unions enable the TMV to be easily removed if required. Servicing Valves should be fitted to the hot and cold supplies to aid maintenance (Clause G11.1). The Arrow Valves TMV is normally supplied with AFL (Automatic Flow Limiting) Servicing Valves – see AFL Data Sheet. These valves enable a strainer only or combined strainer and Automatic Flow Limiting cartridge to be fitted and removed through the side port without disconnecting pipes. The AFL valves are supplied with serviceable 180 µm strainers. In **addition** the cartridges can incorporate an Automatic Flow Limiting facility to assist with water conservation and unbalanced supply pressures. TMVs perform best with equal supply pressures e.g. unvented hot and cold.

Once installed, the outlet temperature must be set with a digital thermometer in accordance with the specification. By default use the TMVA Code of Practice / NHS values.

Specification

Outlet Temperature	30–50°C (Tamperproof adjuster)
Accuracy	$\pm 2^\circ\text{C}$
Max. Hot Temperature	85°C ^{note 1}
Supply Temp. Hot	52–65°C ^{note 1}
Supply Temp. Cold	5–20°C
Min Supply Pressure	0.2 bar dynamic (see flow chart)
Max Supply Pressure	10 bar static, 5 bar dynamic
Maximum Dynamic ΔP	2 bar (between hot and cold) ^{note 2}
Strainer	600 µm (0.6 mm) hot & cold inlets 260 µm ^{note 3} (AFL Service Valves)

Approvals for TMV Model 5213 only
(without AFL service valves and hose)
 WRAS 0401055
 TMV3
 NHS Estates Model Engineering Specification DO8⁴.
 Thermostatic Mixing Valves (Healthcare Premises).

Notes

- To enable isolation should the cold water supply be isolated, the hot supply should be more than 10°C hotter than the desired outlet temperature.
- Where static ΔP is >2 bar, dynamic pressure balance can be achieved with AFL cartridge in high pressure (typically cold) AFL Service Valve.
- The standard strainer supplied in AFL valves is 270 µm, 570 µm optional, the 600 µm strainer is removed. If using combined strainer and flow limiting cartridges, specify colour – see table on right. Note mixed flow = Hot + Cold.
- The TMV valve only (including check valves and strainers) meets the requirements of DO8. Adding the accessories – such as hoses, Service Valves etc – could affect the performance to an extent that the valve does not meet the requirements of the NHS estates specification DO8.



TMV Kit 6

15 mm TMV Kit 6 – supplied with four AFL Servicing Valves & test point

Water Regulations

Clause G 18.5 states the requirement for Thermostatic Mixing Valves –

“Terminal fittings or communal showers in schools or public buildings, and in other facilities used by the public, should be supplied with water through Thermostatic Mixing Valves so that the temperature of the water discharged at the outlets does not exceed 43°C”.

Generally TMVs should be fitted at points of use, i.e. one TMV per outlet. However where a number of outlets are in the same area – e.g. three hand wash basins, these can be served from one TMV – 22 mm). This “group” mixing is **not** recommended for high risk applications – see TMVA code of practice. The mixed outlet should be as short as possible to conform to G18.4 and to minimise the legionella risk. Clause G 18.4 states – *“Where practicable the hot water distribution system should be designed and installed to provide the required flow of water at the terminal fittings to sanitary and other appliances at a water temperature of not less than 50°C (see note) and within 30 seconds after fully opening the tap. This criteria may not be achievable where the hot water is provided by instantaneous or combination boilers”.*
 Note – for public buildings the outlet temperature is 43°C max.

Applications & Temperatures – TMV only

The DO8 document refers to two types of system –

- “High Pressure” dynamic pressure 1–5 bar
- “Low Pressure” dynamic pressure 0.2–1 bar

TMVs perform best with equal supply pressures of 1–3 bar. Above 3 bar use Automatic Flow Limiting cartridge in both Servicing Valves – see table for colour.

For unbalanced supplies - e.g. gravity hot, mains/boosted cold – fit an AFL cartridge in high pressure (cold) Servicing Valve only.

Description	NHS Max. Temp	NHS High Pressure	NHS Low Pressure	Suggested AFL Cartridge (has strainer too)
Wash hand basin	41°C	HP-W	LP-W	2 x Grey (0.07 Lt/s)
Shower	41°C	HP-S	LP-S	2 x White (0.13 Lt/s)
Bidet	38°C	HP-B	LP-B	2 x Grey (0.07 Lt/s)
Bath (unassisted)	44°C	HP-T44	N/A	2 x Blue (0.17 Lt/s)
Bath (assisted)	46°C	HP-T46	N/A	2 x Blue (0.17 Lt/s)

Arrow Valves Ltd reserve the right to change specifications, design and materials at any time without notice. All unit-less dimensions in mm
 © Copyright Arrow Valves Ltd 2002-2012
 Tel 01442 823123 Fax 01442 823234
 www.arrowvalves.co.uk info@arrowvalves.co.uk
 Q:\Arrow Valves\Products\TMV Valves\tmv5213datasheet.docx 16-Mar-12



Thermostatic Mixing Valve

Model 5213 – Datasheet – Page 2 of 2

Cont.

Materials

Body DZR brass - chrome plated
 Hot seat incorporates an EPDM washer enabling drop-tight closure
 Seat Hot seat incorporates an EPDM washer enabling drop-tight closure
 Springs, Strainer Stainless steel

Connection Pipes

Copper – 15 and 22 mm compression fittings
 Plastic – Fittings available for most plastic systems
 Steel - ½” or ¾” FBSPP

Installation

The TMV should be used at points of use and as close as possible to the hot outlet (outlet should reach desired temperature within 30 seconds). Use one TMV per outlet. The TMV can be installed in any orientation (e.g. outlet at top).

A Servicing Valve (excluded from kit) should be fitted to the cold tap such as another AFL valve – which can accept an Automatic Flow Limiting cartridge if required. Additional flexible hoses are available to facilitate installation to the cold tap.

The pipe should be thoroughly flushed and disinfected before installing the TMV. Once installed, the TMV must be commissioned to set appropriate outlet temperature.

Temperature Measurement

A probe digital thermometer with a minimum refresh rate of 4 times a second is recommended.

Cold - the cold temperature can be measured at the cold tap. This should be below 20°C.

Hot - This should be above 55°C.

Mixed - the mixed temperature at the “hot” tap should be set slightly below the maximum permissible temperature – use values in table on p.1 if no other specification is provided.

To adjust the temperature, prise off the plastic cover, invert cover and use as an adjusting tool to rotate the hexagon spindle. A brass lock nut is provided for locking the desired temperature. The plastic cover should then be replaced.

Refer to our web site for TMVA code of practice www.arrowvalves.co.uk

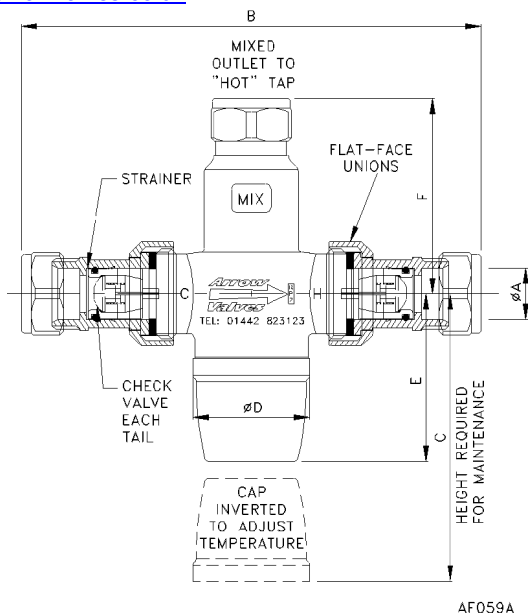

TMV15C5213 - 15 or 22 mm connections
 No servicing valves - disconnection required to clean strainers

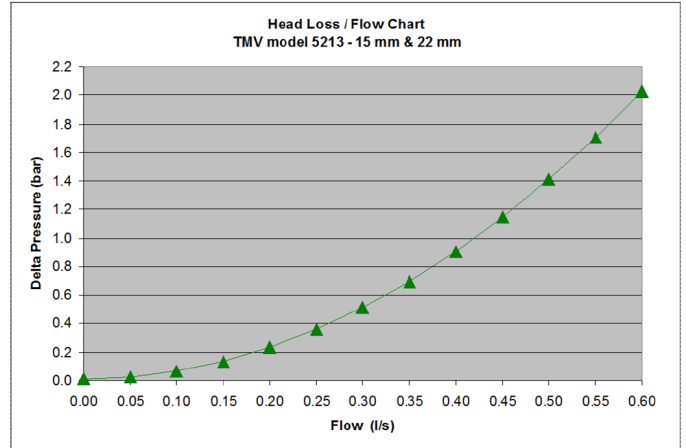

Note – 0.2 bar (2 m) minimum supply pressure.
 Pressure drop includes check valves and strainers.
 Check valves require 0.013 bar to open.
 Flow rate is combined mixed flow with equal hot and cold pressures .
 15 mm suggested max. flow 0.29 l/s (= 2 m/s).
 22 mm suggested max. flow 0.64 l/s (= 2 m/s).

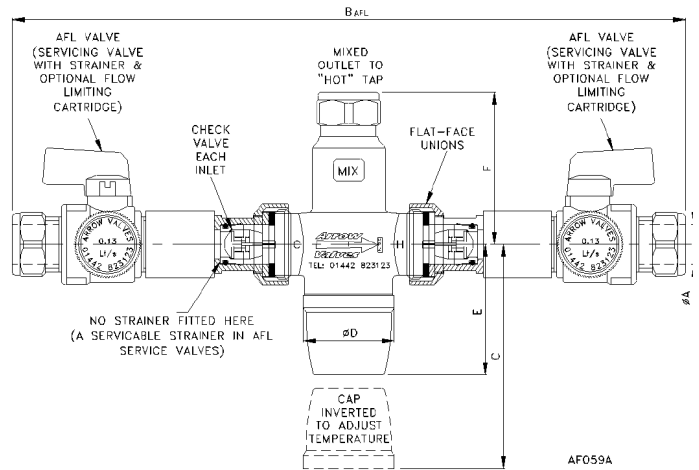

TMV15C5213AFL – 15 mm or 22 mm connections
 With servicing valves – strainers can easily be cleaned in line

Dimension

ØA	B _{AFL}	B _{No AFL}	C	ØD	E	F
15	247	135	75	39	50	57
22	249	149	75	42	50	57

Codes and Descriptions

Size	Code	Description
15 mm	TMV15C5213AFL	Thermostatic Mixing Valve c/w AFL Valves
22 mm	TMV22C5213AFL	Thermostatic Mixing Valve c/w AFL Valves
15 mm	TMV15C5213	Thermostatic Mixing Valve – No Serv. Valves
22 mm	TMV22C5213	Thermostatic Mixing Valve – No Serv. Valves
15 mm	FH15SSN450	Flexible Hose ½” Swivel Nut x Male Spigot 450 mm
15 mm	AFL15CL	AFL Valve Comp Nckel c/w Lever

Factory fitted fittings for range of plastic pipe systems available.

Arrow Valves Ltd

Tel: 01442 823123 Fax: 01442 823234

www.arrowvalves.co.uk

info@arrowvalves.co.uk

Arrow Valves Ltd reserve the right to change specifications, design and materials at any time without notice.

All unit-less dimensions in mm.

© Copyright Arrow Valves Ltd 2001-2012

