

5-10 & 5-16  
PUMPS ARE 3PH  
MCBs FITTED TO  
DUAL PUMP  
MODELS ONLY

TESTED BY \_\_\_\_\_  
DATE \_\_\_\_\_

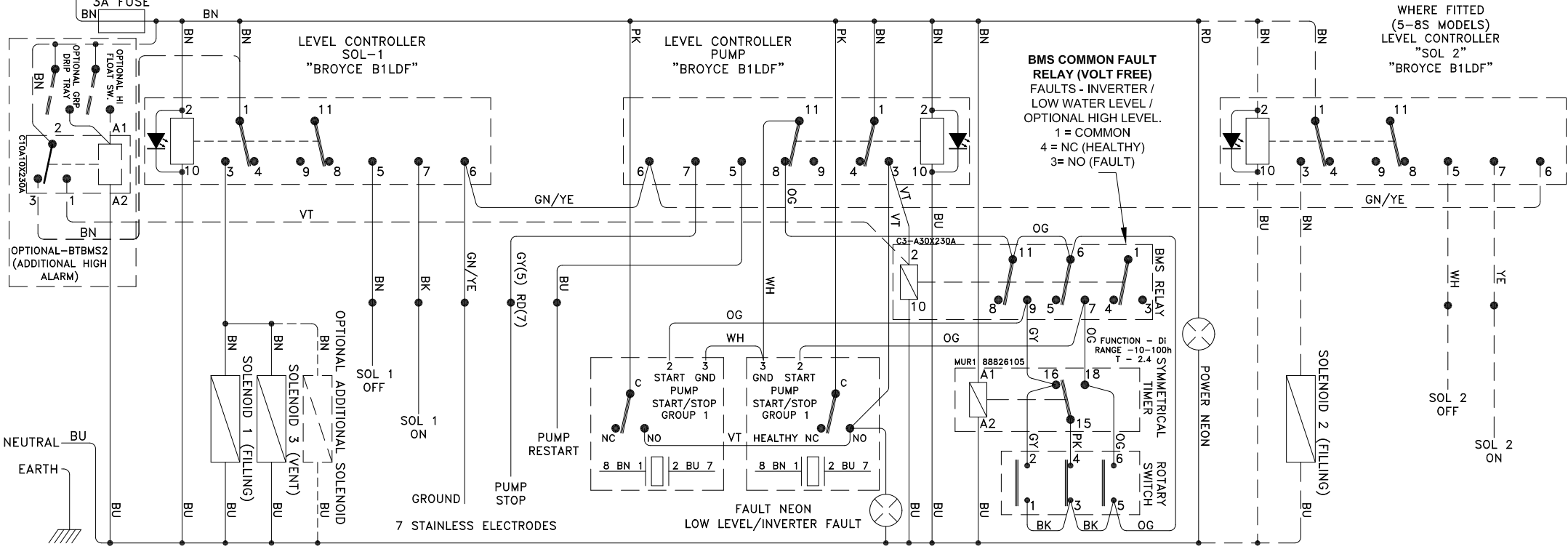

**OPERATION - BT WIRING DIAGRAM VAR SPEED DUTY STANDBY 1 OR 2 FILLING SOLENOIDS**

CISTERN FILLING IS VIA NORMALLY CLOSED SOLENOID VALVES CONTROLLED BY "SOL 1" AND "SOL 2" (WHERE FITTED) LEVEL CONTROLLERS. THE LED ILLUMINATES WHEN THE SOLENOID IS POWERED. SOLENOID 1 OPENS ONCE THE WATER HAS DROPPED BELOW THE "SOL 1 ON" ELECTRODE AND CLOSSES ONCE THE "SOL 1 OFF" ELECTRODE IS SUBMERGED. WHERE FITTED - IF SOLENOID 1 CANNOT MEET THE DEMAND SOLENOID 2 OPENS ONCE THE WATER HAS DROPPED TO "SOL 2 ON" LEVEL.

ONLY ONE PUMP WILL RUN AT ANY ONE TIME. IN "AUTO" MODE THE PUMPS ALTERNATE EVERY 24 HOURS (SWAP AT NO SPECIFIED TIME). IF ROTARY SWITCH SET TO "HAND" LEFT OR RIGHT PUMP WILL RUN UPON DEMAND. IF AN INVERTER OR TRANSDUCER FAULT OCCURS, THE BMS RELAY ACTIVATES AND FORCES THE HEALTHY PUMP TO RUN UPON DEMAND.

THE PUMPS ARE CONTROLLED BY PRESSURE TRANSDUCERS AND LOW LEVEL "PUMP" CONTROLLER. THE "PUMP" CONTROLLER CUTS POWER TO THE PUMPS IF THE CISTERN IS ALMOST EMPTY. THE LED ILLUMINATES WHEN THE "PUMP STOP" ELECTRODE IS EXPOSED - THE PUMP STOPS. THE PUMP RESTARTS ONCE THE "PUMP RESTART" ELECTRODE IS SUBMERGED. ONCE THE PRESSURE VESSEL IS RECHARGED AND NO FLOW IS DETECTED, THE PUMPS RUNS SLOW FOR A PERIOD THEN STOPS. GO TO [arrowvalves.co.uk](http://arrowvalves.co.uk) FOR FAULT FINDING CHART.

T. 01442 823123  
[arrowvalves.co.uk](http://arrowvalves.co.uk)  
AM135C 25/10/10



ARROW VALVES LTD  
68 HIGH STREET  
TRING HERTS  
HP23 4AG  
Tel: 01442 823 123 Fax: 01442 823 234  
e-mail: [info@arrowvalves.co.uk](mailto:info@arrowvalves.co.uk)  
web: [www.arrowvalves.co.uk](http://www.arrowvalves.co.uk)



TITLE:  
**BT WIRING DIAGRAM VAR SPEED DUTY STANDBY**

DRN: SHG CHECKED BY: \_\_\_\_\_ DATE: \_\_\_\_\_

©2009

This drawing is the property of Arrow Valves Ltd and must not be copied without prior written permission

MATERIAL: CARD 160 g/sqm

FINISH: LAMINATED SCALE: 100%

DRG No: AM135C DATE: 25/10/10