

Double Check Valve with Optional Flow Limiter

Model ED235 Chrome - Female x Male & Male x Female - Data Sheet

Description

Double Check Valves (type ED) with chrome plated brass body. The female inlet type are primarily intended for backflow protection from flexible hoses and are usually fitted between the servicing valve (or tap) and a hose. The male inlet types are often suitable for fitting to a tap tail.

Double Check Valves (type ED) are suitable for Fluid Category 3 risks, such as domestic bath / shower hoses. *“Domestic” includes hotels but excludes healthcare.* This risk arises where the outlet can become submerged.

These valves can quickly be fitted. An EPDM washer is supplied with each device to facilitate fitting to flat-faced outlet.

Automatic Flow Limiter (ED15FM235 only)

For showers, an Automatic Flow Limiting cartridge is recommended. This will limit the maximum flow irrespective of the supply pressure (between 1 – 10 bar). The Cartridge can be incorporated in the Double Check Valve or is available separately. A white cartridge (0.13 Lt/s) is commonly used. Black (0.1 Lt/s) and Blue (0.17 Lt/s) are optional. See also *“Equi-Flow” (model AFLE) datasheet for further information on Automatic Flow Limiter for shower hoses.*

Pipe Connections

The ED20FM235 has a female inlet and the male outlet. This configuration is ideal for washing and dishwashing machine hoses. Washing machine servicing valves normally have a 3/4" male thread (DN20), permitting the direct fitting of this check valve. All threads are BSP parallel.

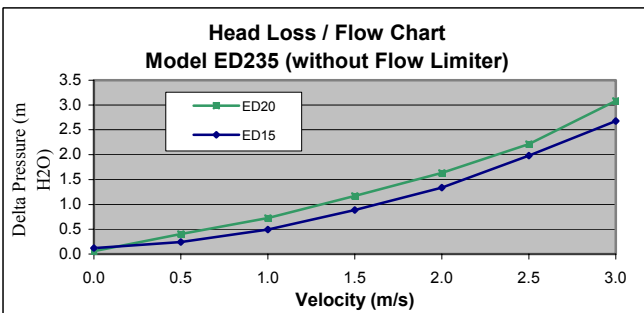

Notes - Velocity based on flow of water through the bore of copper tube table X. See Flow Table to find the actual flow rate.

Dimensions

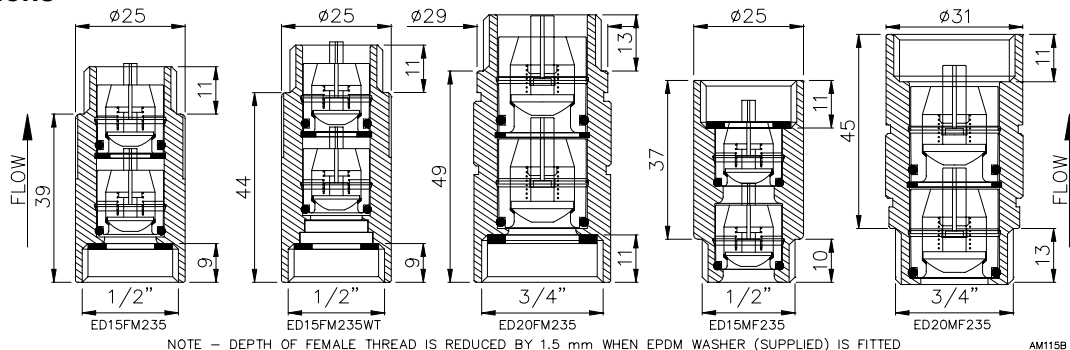

Codes and Descriptions

Size	Code	Description	Typical Application
DN15	ED15FM235	Double Check Valve F inlet - M Chrome	Shower hose – between tap outlet and start of hose
DN15	ED15FM235WT	DCV Flow Limiter White 0.13 Lt/s Chrome	Shower hose – between tap outlet and start of hose. Includes flow limiter
DN20	ED20FM235	Double Check Valve F inlet - M Chrome	Washing and dishwashing machine between valve and hose inlet
DN15	ED15MF235	Double Check Valve M inlet - F Chrome	1/2" (e.g. basin, sink or modern bath) Tap tail
DN20	ED20MF235	Double Check Valve M inlet - F Chrome	3/4" (e.g. some bath) Tap tail



ED15FM235 Double Check Valve designed specifically for bath shower hoses – with optional Automatic Flow Limiting cartridge. Female Inlet, EPDM washer supplied

Water Regulations

Double Check Valves are suitable for backflow protection of Fluid Category 3 risks.

Clothes and dish washing machines must have Fluid Category 3 protection for use in a house and Category 4 or 5 for other uses (see www.arrowvalves.co.uk click on Tutorial 4).

The Water Regulations generally require “Point of Use” protection. The local water company can advise.

Materials

Body	Brass – chrome plated
Springs	Stainless steel
Cartridges	POM
Elastomers	NBR

Specification

Pressure	16 bar max.
Test Pressure	16 bar (reverse)
Opening Pressure	0.026 bar
Temperature	Continuous - 65° C Intermittent - 90° C

Approval

(ED235 complete)	KIWA UK 0810703
(ED235 complete - with optional flow regulator)	KIWA UK A040756

Arrow Valves Ltd

Tel: 01442 823123 Fax: 01442 823234

www.arrowvalves.co.uk info@arrowvalves.co.uk

Arrow Valves Ltd reserve the right to change specifications, design and materials at any time without notice. All unit-less dimensions in mm. © Copyright Arrow Valves Ltd 2001-2011

