

# “WaterPoint” - Standpipe Assembly - Model SPWP – Tamperproof Hose Bib Tap with Shelf Category 3 - Datasheet – Page 1 of 2

## Description

Tamperproof Standpipe enclosure with Hose Union tap for filling of watering cans and buckets in areas where the risk is Fluid Category 3. The unit is similar to model SPED, with the addition of a retractable bucket shelf and increased height; facilitating access to the tap and accepting tall buckets.

The bucket shelf retracts into the top cap when closed, thereby minimising the risk of injury. The sliding cover operates within its own foot print, is immune to swinging in the wind and is designed to prevent trapped fingers. The cover may be locked in its mid position preventing the fitting of a hose during prescriptive hosepipe bans. The Standpipe can be supplied with a Self Closing Tap, in place of Hose Union tap - SPWPSC

When closed, the Standpipe conceals the tap and hose connector. Tamper-proofing is achieved using the optional padlock. The Standpipe has two operating positions; mid-position - front cover slides down to expose the Hose Union tap leaving the hose connection concealed, and lower-position - front cover slides down further to provide an integral bucket shelf. The bucket shelf allows users to rest watering cans or buckets during filling. The hose can be left connected in all positions. A Padlock is required to secure the cover in the top (shut) and mid positions.

The robust galvanised steel housing provides a degree of frost protection. All panels are nylon powder coated dark green, whilst the handle, staples and fasteners are stainless steel. The bucket shelf is stainless steel.

The Standpipe is supplied fully assembled and tested. A DZR Brass compression fitting for MDPE is included and all serviceable components are accessible from the front.

The Standpipe can be bolted to a concrete floor or mounted on the optional “Pile”. The galvanised Pile can be buried in soft ground or in an area to be subsequently concreted. M12 stainless bolts are provided to bolt the Pile and Standpipe together. The mating flanges would normally be positioned 30 mm above ground but for aesthetic reasons in gardens the flanges may be buried up to 50 mm beneath the soil surface.

The Standpipe features a Double Check Valve providing Fluid Category 3 protection and affords a good flow even in low pressure areas by virtue of high-flow cartridges. In potentially prolonged freezing conditions - isolate supply at source - and leave tap open.

## Specification

Pressure Supply	10 bar max.
Supply Size	20 or 25 MDPE (15 or 22 Cu) ¾” Male if fitting removed.
Outlet tap	High quality heavy pattern bib tap with hose connector (O-ring seal). The common ¾” thread on both the ½” and ¾” tap allows a ¾” hose to be fitted to the ½” tap and vice versa.

*See page 2 for dimensions*

## Materials

Standpipe and Panels	2 mm steel – galvanised & powder coated nylon dark green RAL6005
Shelf	304 stainless steel
Pile	2 mm steel – galvanised hot dip
MDPE Connectors	DZR brass (no insert required)
Fasteners & Handle	Stainless steel A2
Double Check Valve	DZR brass CZ132
Bib Tap BS1010/2	Forged brass

*Model SPWP – Cover shown in lower position - filling watering can*

*Freestanding Standpipe with Hose Union tap. Bucket shelf (integral in sliding front cover) provides a rest whilst filling watering cans and buckets. Shelf retracts into top cap when closed*

*Self Closing Tap available in place of HU Tap*

*The Standpipe includes a Double Check Valve, providing Fluid Category 3 protection*



## Water Regulations

The assembly complies with the requirements of the Water Regulations when installed and used correctly. The Double Check Valve assembly (type ED) fitted provides adequate protection against Fluid Category 3 risks - these risks are largely domestic. For Category 5 risks (waste bin washing, farm yards, abattoirs, etc) the Standpipe should be supplied via a Break Tank with Type AB air gap - see BTAB pump set. The local water supplier should be consulted regarding the level of protection required.

## Applications (Fluid Categories 1 – 3)

- Filling buckets e.g. campsites
- Filling watering cans e.g. cemeteries
- Private, residential & public gardens
- Retail parks
- Golf courses & bowling greens
- Caravan sites
- Commercial & industrial yards (often Fluid Cat. 5)
- Garden centres (can be Fluid Cat 4)
- Marinas (often Fluid Category 5 for large craft)
- Schools & car parks
- Garages & vehicle washing areas (often Fluid Cat. 4)

## Connection Pipes

The supply pipe should be laid 750 mm below ground (G7.7). The pile has several slots to allow MDPE pipes to be curved up (min. radius 20D), thus avoiding underground connections.

The Pile and Standpipe can accommodate two pipes; thus allowing the supply to continue to other Standpipes or fittings. Again all the connections for the Tee are above ground and serviceable. In contaminated ground areas (brown sites) plastic pipe without barrier should not be used. Compression connections for copper tube available.

## Arrow Valves Ltd

Tel: 01442 823123 Fax: 01442 823234

arrowvalves.co.uk  
info@arrowvalves.co.uk

Arrow Valves Ltd reserve the right to change specifications, design and materials at any time without notice. All unit-less dimensions in mm.

© Copyright Arrow Valves Ltd 2001-2011



# “WaterPoint” - Standpipe Assembly - Model SPWP – Dimensions - Datasheet – Page 2 of 2

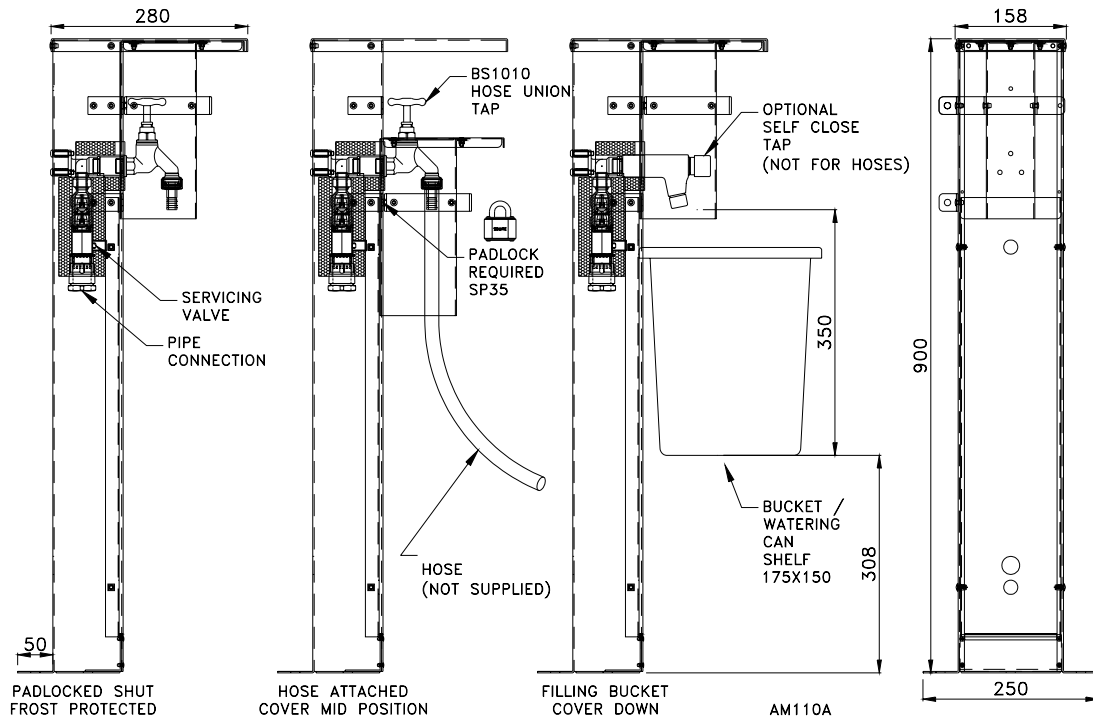

## Pile (Optional)

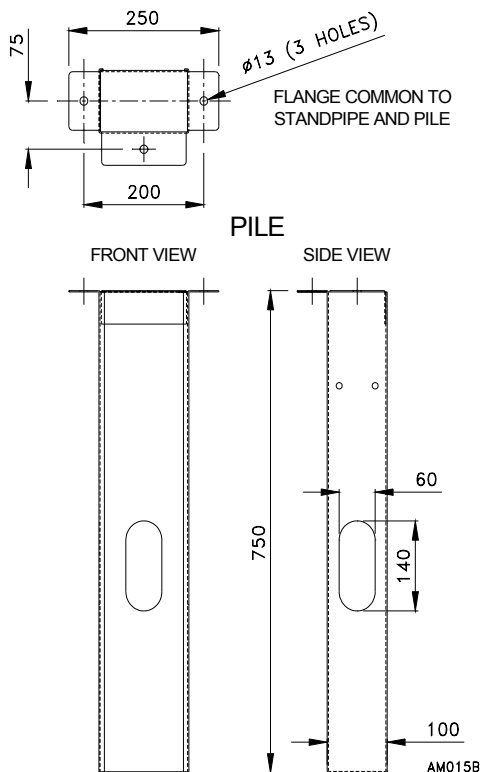

## Hose Connectors (1 supplied)

Supplied with the corresponding hose connector as standard. The common 3/4" thread on the outlet of the 1/2" and 3/4" bib tap allows a 3/4" hose connector to be fitted to the 1/2" tap and vice versa.

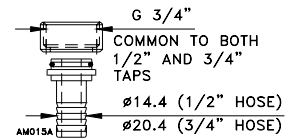

## Codes and Descriptions

Size	Code	Description
1/2"	SPWP15x20	1/2" WaterPoint Standpipe 20 MDPE Inlet
1/2"	SPWP15X25	1/2" WaterPoint Standpipe 25 MDPE Inlet
3/4"	SPWP20x25	3/4" WaterPoint Standpipe 25 MDPE Inlet
	SPWPSC20	WaterPoint Standpipe Self Close 20 MDPE
	SPWPSC25	WaterPoint Standpipe Self Close 25 MDPE
	SP35	Padlock c/w 2 Keys KA - Std Shackle
	SPCP1	Squire Padlock Combination - High Anti Rust
All	SPPILE	Pile for Soft Ground c/w M12 SS Fasteners
DN20	DB20IL15	Pipe Int. DB 1/2" Inter-Lock Hose Conn.
20 mm	BVBG20	Servicing Valve Below Ground 20 MDPE
20 mm	BVBGM20	Serv. Valve Below Ground Meter 20 MDPE
25 mm	BVBG25	Servicing Valve Below Ground 25 MDPE
25 mm	BVBGM25	Serv. Valve Below Ground Meter 25 MDPE

## Notes

To specify an alternative inlet connection, replace the last two digits. E.g. SPWP15x25 is a 1/2" (DN15) Standpipe with 25 mm MDPE inlet. SPWP15x15 is a 1/2" (DN15) Standpipe with 15 mm copper compression inlet.

## Options

- Pile for mounting Standpipe in soft ground
- Rustproof Padlock c/w 2 keys or combination
- Powder coating (nylon). Standard colour - dark green - others available. Special order, min qty 10
- Complete units in stainless steel – special order, min qty 10
- DB Pipe Interrupters (for porous hoses for house gardens – not for self close tap)

## Arrow Valves Ltd

Tel: 01442 823123 Fax: 01442 823234

arrowvalves.co.uk  
info@arrowvalves.co.uk

Arrow Valves Ltd reserve the right to change specifications, design and materials at any time without notice.  
All unit-less dimensions in mm.

© Copyright Arrow Valves Ltd 2001-2011

